

SENSORI

SMARTTOUCH



Digital Shower Controller Installation Instructions

Keep for future reference



Contents

Important Information	3
Specification	6
Dimensions	7
Main Components	8
General Installation Information	9
Typical Suitable Installations	10
Digital Mixer Processor Installation	14
Digital Controller Installation	19
Commissioning	22
Remote Start/Stop Installation	23
Quick Start	24
General Maintenance	25
Spare Parts	26
Fault Diagnosis	27
Disposal & Recycling	29

Important Information

This book contains all the necessary installation instructions for your Sensori SmartTouch Digital Mixer Shower – please read them carefully.

Care taken during the installation will provide a long and trouble-free life from the Sensori Digital Mixer Shower. The installation must be in accordance with Water Regulations and Bylaws.

BS EN 806 RECOMMENDS THAT THE TEMPERATURE OF STORED WATER SHOULD NEVER EXCEED 65°C. A stored water temperature of 60°C is considered sufficient to meet all normal requirements and will minimise the effects of scale in hard water areas.

STANDARDS AND APPROVALS

The Digital Mixer Processor is an independently mounted electronic control and complies with current British and European safety standards for household and similar electrical appliances. Meets with Compliance with European New Approach Directives (CE).

DECLARATION OF CONFORMITY

This VADO Sensori product, in conjunction with the controller, complies with the essential requirements and other relevant provisions of the Low Voltage Directive (2014/35/EU) and the EMC Directive (2014/30/EU) and the RE Directive (2014/53/EU).

THE SHOWER HEADS AND OUTLET DEVICES ARE SAFETY CRITICAL PARTS OF YOUR SHOWER. FAILURE TO USE GENUINE APPROVED VADO PARTS MAY CAUSE INJURY AND INVALIDATE YOUR GUARANTEE.

Please read this book thoroughly and familiarise yourself with all instructions before commencing installation and keep it for future reference. The shower installation **MUST** be carried out by a suitably qualified person, following the sequence of this instruction book.

Important Information

PLUMBING

Supply pipes **MUST** be flushed to clear debris before connecting the Digital Mixer Processor. Layout and sizing of pipework must be such that when other services are used, pressures at the shower inlets **DO NOT** fall below the recommended minimum.

DO NOT use excessive force when making connections to the Digital Mixer Processor.

DO NOT choose a position where the Digital Mixer Processor will become frozen.

DO NOT connect the Digital Mixer Processor to any form of tap or fitting not recommended by the manufacturer.

The shower head or other approved VADO device **MUST** be regularly cleaned to remove scale and debris.

If it is intended to operate the shower in areas of hard water (above 200 ppm temporary hardness), a scale inhibitor may have to be fitted. For advice on the scale inhibitors, please contact Customer Services.

DO NOT operate the Digital Mixer Processor outside the guidelines as laid out in 'site requirements' and 'specifications'.

DO NOT connect to a combination cylinder unless the minimum cold storage can be achieved as the shower can deliver up to 16 litres/min.

DO NOT connect the low pressure Digital Mixer Processor to the mains water supply as this will damage the unit. When installed, the top of the low pressure Digital Mixer Processor **MUST** be at least 100mm lower than the base of the cold-water cistern to prevent the unit running dry.

Important Information

A dedicated cold-water supply **MUST** be taken directly from the cold-water cistern to the low pressure Digital Mixer Processor. This draw-off must be on the opposite side of the cistern to the float operated valve to reduce the risk of air entering the unit. The infill to the cistern should be checked to ensure an adequate infill rate occurs.

ELECTRICAL

THE INSTALLATION MUST COMPLY WITH BS 7671 REQUIREMENTS FOR ELECTRICAL INSTALLATIONS' (IEE WIRING REGULATIONS). MAKE SURE METAL INCOMING HOT AND COLD-WATER SUPPLIES TO THE DIGITAL MIXER PROCESSOR UNIT ARE ADEQUATELY EARTH BONDED.

Do not turn on the electrical supply until the plumbing connections have been completed. Only then can the electricity be switched on to undertake commissioning. The Digital Mixer Processor must not be operated dry without water.

THE DIGITAL MIXER PROCESSOR MUST BE PERMANENTLY CONNECTED TO A 3 AMP FUSED CONNECTION UNIT AND BE PROVIDED WITH MEANS FOR DISCONNECTION. INCORPORATED IN THE FIXED ELECTRICAL WIRING IN ACCORDANCE WITH CURRENT WIRING REGULATIONS.

A 30mA Residual Current Device (RCD) **MUST** be included in the electrical circuit. This may be part of the consumer unit or a separate unit.

If the Digital Mixer Processor is to be installed within a bath or shower room the electrical installation **MUST** conform to Part P Building Regulation Requirements for Special Locations.

The Digital Mixer Processor **MUST** only be used with the AC power supply cable provided. If this supply cable is damaged, it must be replaced by a VADO engineer or similar qualified persons to avoid a hazard.

Specification

	Digital Processor Low Pressure / Gravity System (Single & Dual Outlet)	Digital Processor High Pressure System (Single & Dual Outlet)
Electrical		
Mains Supply	230V 50Hz	230V 50Hz
Maximum Load	125W	30W
Water		
Inlet Connections	15mm Push-Fit Connectors	15mm Push-Fit Connectors
Outlet Connections	15mm Push-Fit Connectors	15mm Push-Fit Connectors
Water Pressures		
Maximum Static	100 kPa (1bar/10m head)	500 kPa (5 bar)
Minimum Running	1 kPa (0.01bar/0.1m head)	100 kPa (1 bar)
Supply Pressure Differential	Nominally Equal $\pm 20\%$	Nominally Equal $\pm 20\%$
Temperatures		
Hot Water Temperature	55°C - 65°C	55°C - 65°C
Cold Water Temperature	1°C - 20°C	1°C - 20°C
Ambient Temperature	5°C - 40°C	5°C - 40°C
Showering Temperature	32°C to 47°C*	32°C to 47°C*
Adjustment Range	(* Max can be restricted)	(* Max can be restricted)
Splashproof Rating	IP24	IP24

Dimensions

DIGITAL CONTROLLER (Including wall fixing bracket)

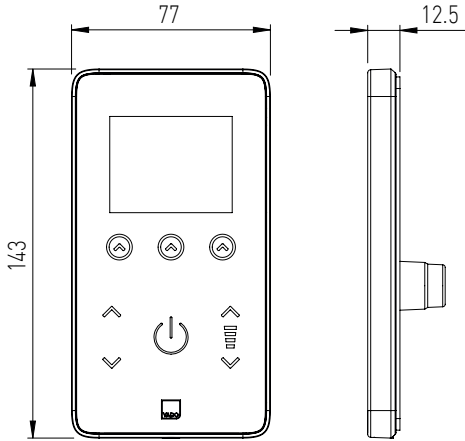

DIGITAL MIXER PROCESSOR (Single & dual outlet variants)

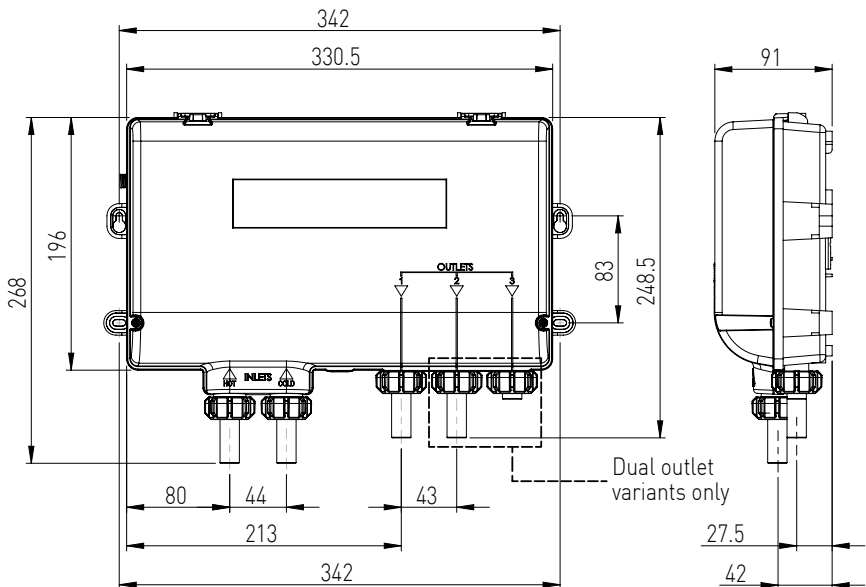

Main Components

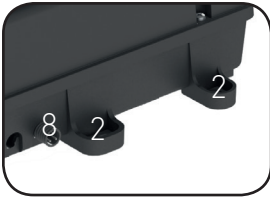

- | | |
|---|---|
| <ol style="list-style-type: none"> 1. Digital Mixer Processor Cover 2. Digital Mixer Processor Fixing positions 3. Digital Mixer Processor AC Power Lead 4. 15mm push fit connectors with Isolating valves 5. 15mm push fit connectors 6. Digital Mixer Processor Inlets (HOT & COLD) | <ol style="list-style-type: none"> 7. Digital Mixer Processor Outlets (*) 8. Digital Mixer Processor Data Cable connector 9. Digital Controller 10. Controller Fixing Bracket 11. 10m Data Cable 12. Start/Stop Remote 13. Start/Stop Wall Bracket |
|---|---|

[*] The number of outlets will vary depending on the configuration of the Digital Mixer Shower purchased.

General Installation Information

IMPORTANT: THE INSTALLATION MUST BE CARRIED OUT IN ACCORDANCE WITH THESE INSTRUCTIONS AND MUST BE UNDERTAKEN BY A QUALIFIED COMPETENT PERSON.

IMPORTANT: THE SHOWER MUST NOT BE POSITIONED WHERE IT WILL BE SUBJECTED TO FREEZING CONDITIONS.

The Digital Mixer Processor may be installed in a loft space, under the bath or in a convenient cupboard space, provided there is enough room for maintenance and the ambient temperature does not go above or below the stated parameters as listed on Page 6. Safe and easy access to the Digital Mixer Processor should always be available.

When planning the installation ensure that the distance between the Digital Mixer Processor and Digital Controller is within the range of the 10m data cable supplied, ensuring that the data cable routing is taken into consideration.

Ensure that the Digital Mixer Processor is installed in a position that will minimise the length of pipe run between the Digital Mixer Processor outlets and the shower head/accessory fittings. The length of pipework running from the Digital Mixer Processor to the shower head/accessory fittings will influence the showering temperature and the response time when changing the water temperature on the Digital Controller. The shorter the length of pipework the better the Digital Mixer Processor will respond.

When installing the Digital Mixer Processor in an area not regularly accessed, consideration for potential leaks must be considered.

While such events are unlikely, it is advisable to periodically check the installation for traces of water on or around the processor unit. If possible, site the Digital Mixer Processor in a location where any leak would be contained or routed to avoid areas sensitive to water damage.

Isolation valves are integrated into the push connection fittings supplied for the hot & cold inlets. Ensure that after installation these valves are left in the fully open position as failure to do this will result in poor flow performance from the Digital Mixer Shower.

All pipe work **MUST** be rigidly supported to avoid any strain on the connections and vibrations during use.

Long inlet pipework (dead-legs) should be kept to a minimum to avoid showering temperature fluctuations

DO NOT connect the Digital Processor to a gravity hot supply and a mains cold supply (or vice versa).

General Installation Information

The pipework should be installed such that the flow is not significantly affected by other taps and appliances being operated elsewhere on the premises.

THERE ARE NO USER-SERVICEABLE COMPONENTS BENEATH THE COVER OF THE DIGITAL MIXER PROCESSOR.

Typical Suitable Installations

HIGH PRESSURE SYSTEM - INSTANTANEOUS HOT WATER SYSTEMS, COMBINATION BOILERS (FIG.1)

The high pressure Digital Mixer Processor **MUST** be installed with a multipoint gas water heater or combination boiler of a fully modulating design (i.e. where the water draw-off rate indirectly controls the gas flow rate to the burner).

A drop tight pressure reducing valve **MUST** be fitted if the supply pressures exceed 500kPa (5 bar) running.

An expansion vessel **MUST** be fitted, (and regularly maintained) if any form of backflow prevention device is fitted i.e. PRV. This will ensure that excess expansion or pressure pulses do not damage the product. This may already be installed within the boiler (check with manufacturer) and is in addition to the normally larger central heating expansion vessel.

The layout and sizing of pipework **MUST** be such that nominally equal inlet supply pressures are achieved, and the effects of other draw-offs are minimised.

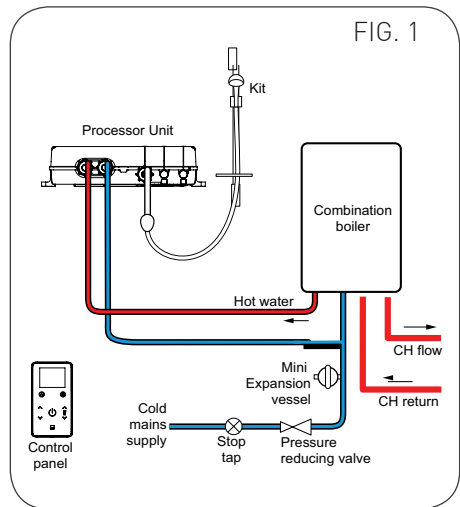

Typical Suitable Installations

NOTE: Combination boilers are not always able to supply an adequate flow rate of hot water, particularly in winter. VADO recommends fitting a flow regulator (supplied with the Shower) into the Hot inlet of the High Pressure Digital Mixer Processor prior to installation. Refer to the table for the correct flow regulator to use for your combination boiler.

Boiler Rating	Regulator
24 to 30kW	7 L/min White/Green
30 to 36kW	9 L/min White/Orange
36kW +	None required

TO FIT FLOW REGULATOR (FIG. 2)

Unscrew the hot inlet nut and remove the inlet pipe, O-ring seal, inlet filter and flow regulator housing.

Fit the flow regulator into the flow regulator housing.

Refit the flow regulator housing, inlet filter, O-ring seal and inlet pipe, secure with the hot inlet nut.

NOTE: The hot inlet nut only requires to be hand tightened.

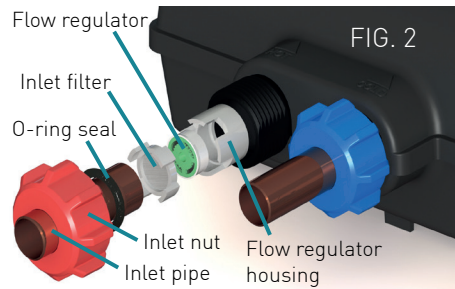

HIGH PRESSURE SYSTEM - UNVENTED MAINS PRESSURE CYLINDERS (FIG.3)

The high pressure Digital Mixer Processor **MUST** be installed with an unvented, stored hot water cylinder.

For systems with no cold water take off after the appliance reducing valve, it will be necessary to fit an additional drop tight pressure reducing valve when the mains pressure is over 500kPa (5 bar). The drop tight pressure reducing valve **MUST** be set at the same value as the unvented package pressure reducing valve.

NOTE: An additional expansion vessel (FIG.3) may be required if a second

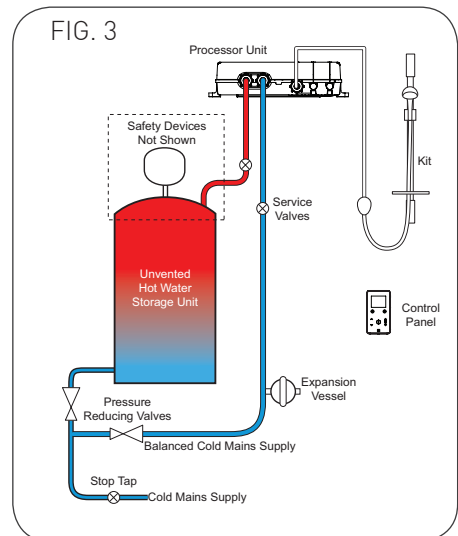

Typical Suitable Installations

pressure reducing valve is installed. This does not apply to packages with a cold take off after the pressure reducing valve to the cylinder.

The layout and sizing of pipework **MUST** be such that nominally equal inlet supply pressures are achieved, and the effects of other draw-offs are minimised.

HIGH PRESSURE SYSTEM - MAINS PRESSURISED THERMAL STORE SYSTEM (FIG.4)

The high-pressure system **MUST** be fitted with a tempering valve (BLENDER VALVE).

The appliance must be capable of raising the temperature of the incoming water to a minimum of 55°C and delivering a flow rate of not less than 8 L/min.

A drop tight pressure reducing valve **MUST** be fitted if the supply pressures exceed 500kPa (5 bar) running.

An expansion vessel (shown in **FIG.4**) **MUST** be fitted, and regularly maintained, to ensure the unit is not damaged by excess pressures. This may already be installed externally or internally within the thermal store (check with thermal store manufacturer).

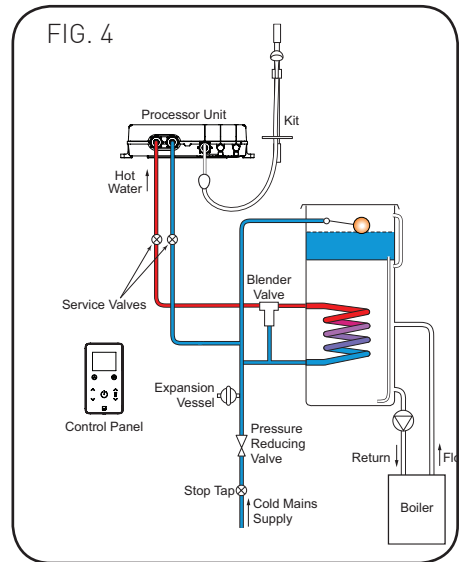

Typical Suitable Installations

LOW PRESSURE SYSTEM - GRAVITY FED SYSTEM (FIG.5)

IMPORTANT: Pipework layouts and connections **MUST** be such that other draw-offs will not affect water supplies to the Digital Mixer Processor.

IMPORTANT: ONLY INSTALL THE LOW-PRESSURE DIGITAL MIXER SHOWER WITH A GRAVITY FED SYSTEM. NEVER INSTALL A HIGH-PRESSURE DIGITAL MIXER SHOWER WITH A GRAVITY FED SYSTEM.

IMPORTANT: THE MINIMUM HEAD FOR OPERATION OF THE DIGITAL MIXER PROCESSOR IS 100MM. FOR CORRECT OPERATION THE DIGITAL MIXER PROCESSOR MUST NOT BE SITED MORE THAN 5 METRES AWAY FROM THE HOT WATER CYLINDER.

The low pressure Digital Mixer Processor **MUST** be fed from a cold-water cistern and hot water cylinder providing nominally equal pressures.

For the operation of the shower only, it is recommended that the cold-water storage cistern can hold at least 114 litres (25 gallons). Where other hot and cold outlets are likely to be in use simultaneously, the storage capacity should be increased to 228 litres (50 gallons) in accordance with BS EN 806.

Shared supplies may lead to air locking or water starvation. It is therefore best practice to have independent hot and cold supplies to the digital mixer processor.

If the hot water draw-off is incorrectly positioned, air may be drawn into the hot supply from the vent pipe causing spluttering, temperature fluctuations at the shower head.

Any draw-off for the Digital Mixer Processor must point **DOWN** (to avoid air-lock problems) and must be **BELOW** the vent pipe tee.

Failure to correctly position the draw-off will result in poor performance or other problems with the Digital Mixer Processor.

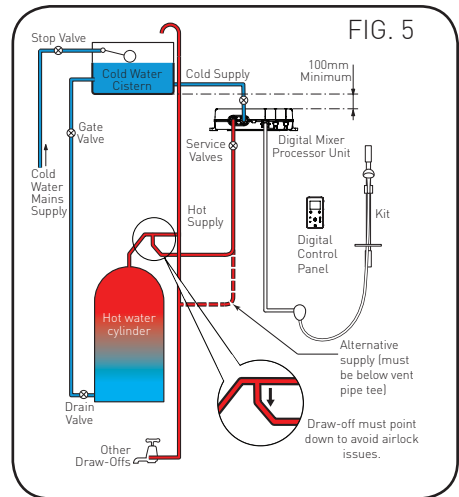

Digital Mixer Processor Installation

The Digital Mixer Processor **MUST** only be positioned as shown.

The Digital Mixer Processor can be mounted on a horizontal surface in any orientation (**FIG.6**).

When mounting on a vertical surface the Digital Mixer Processor outlet **MUST** be at the bottom (**FIG.7**). Failure to position the unit correctly could result in a significant reduction in performance.

Decide on the position for the Digital Mixer Processor. Position the Digital Mixer Processor in a dry, well ventilated area.

The Digital Mixer Processor **MUST** always be positioned either flat on a suitable surface or on a wall so that there is easy access for installation and maintenance.

Mark the four locating screw points for the base. If fixing to brick or a stud partition drill and plug the wall. (The wall plugs provided are suitable for most brick walls — use an appropriate masonry drill, but if the wall is plasterboard or a soft building block, you must use suitable wall plugs and an appropriate drill bit).

Secure the Digital Mixer Processor in position using the 4 screws supplied (**FIG.8**).

If the Digital Mixer Processor is installed in a loft area the following requirements must be met for future servicing purposes:

1. There must be no risk of the Digital Mixer Processor or water pipe becoming frozen.
2. The Digital Mixer Processor **MUST NOT** be covered with any form of insulating material that may give rise to electrical circuits overheating during periods of high ambient temperature.

Ensure sufficient space is left surrounding the processor unit to allow for pipework, connections and maintenance

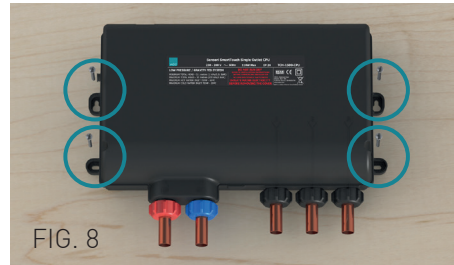

Digital Mixer Processor Installation

3. A safe means of access **MUST** be provided into the loft, e.g via a fixed loft ladder.
4. The Digital Mixer Processor **MUST** be installed in an accessible and safe location.
5. Ceiling joists **MUST** be adequately boarded to provide safe and unobstructed access to, from and around the Digital Mixer Processor.
6. There **MUST** be adequate lighting in the loft for servicing purposes.

NOTE: If mounting the Digital Mixer Processor in a loft, it is worth considering building a catchment tank with an overflow pipe directed to an external point. In the unlikely event of a problem occurring with the Digital Mixer Processor this will give a visual indication of any failure.

PLUMBING CONNECTIONS

IMPORTANT: PLUMBING/PIPE INSTALLATION TO BE CARRIED OUT BEFORE ELECTRICAL WIRING INSTALLATION.

IMPORTANT: THE FITTINGS ON THE INLET AND OUTLETS ARE THE PUSH-FIT TYPE. THE PIPEWORK MUST BE CUT WITH A PIPE CUTTER AND ALL BURRS AND ROUGH EDGES REMOVED FROM THE END OF THE TUBE. THE FITTINGS CAN BE USED WITH COPPER AND PLASTIC PIPE.

IMPORTANT: ALL PIPEWORK SHOULD BE INSULATED. DO NOT ATTEMPT TO INSULATE OR COVER THE DIGITAL PROCESSOR. DO NOT use jointing compounds on any pipe fitting for the installation.

DO NOT solder fittings near the shower unit as heat can transfer along pipework and damage components.

FIG.9 shows the plumbing connections layout.

(*) The number of outlet connections will vary depending on the configuration of the Digital Mixer Shower purchased.

If using chrome plated copper pipe, remove the first 25mm of plating completely from the connecting surfaces. If not completely removed, then the collet will not grip the pipe and under pressure the pipe may be forced out.

Before completing the connection of the water supplies to the inlets of the Digital Mixer Processor, flush out the pipework to remove all swarf and system debris.

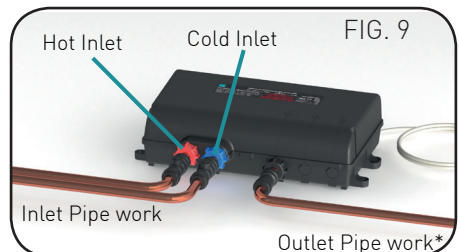

Digital Mixer Processor Installation

1. Turn off the water supplies either at the mains stop valve or the isolating stop valve.
2. Having decided on the position of the unit and direction of pipe entry, complete the pipework to the Digital Mixer Processor.
3. Check for leaks before connecting the pipework to the Digital Mixer Processor.
4. Insert the incoming pipework into the 15mm push-fit connectors (**FIG.10**).
5. Check that the isolating valves on the inlet connectors are fully open (turn fully clockwise) (**FIG.11**).

For products that have more than one outlet then the above procedure of fitting the pipe work will need to be conducted for each outlet.

ELECTRICAL CONNECTIONS

IMPORTANT: BEFORE ANY ELECTRICAL WORK IS ATTEMPTED, ENSURE THE ELECTRICITY SUPPLY IS ISOLATED AT THE MAINS SWITCH.

IMPORTANT: ELECTRICAL INSTALLATION MAY ONLY BE CARRIED OUT BY A QUALIFIED PERSON

Connect the Digital Mixer Processor AC Power Lead to a double pole 3 Amp Switched Fused Spur (**FIG.12**), incorporated in the wiring circuit, in accordance with current wiring regulations.

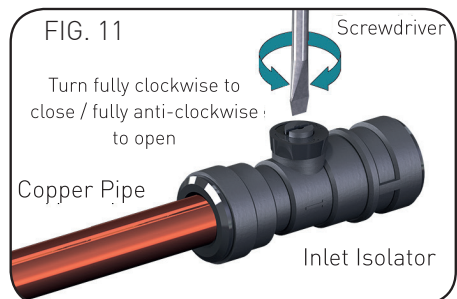
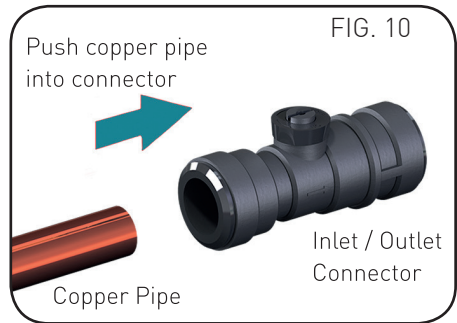

Digital Mixer Processor Installation

NOTE: The 3 Amp Fused Spur **MUST** be in a dry, easily accessible position. Access to the fused spur is required for servicing and maintenance.

Neutral cable marked N Blue.

Live cable marked L Brown.

DO NOT switch on the electricity supply until all the pipe connections have been tested for leaks and the commissioning procedure has been followed.

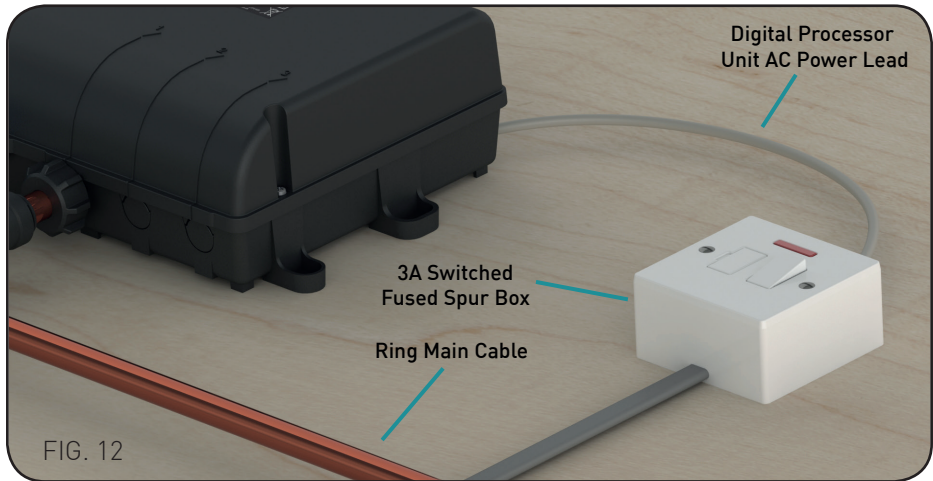

Digital Mixer Processor Installation

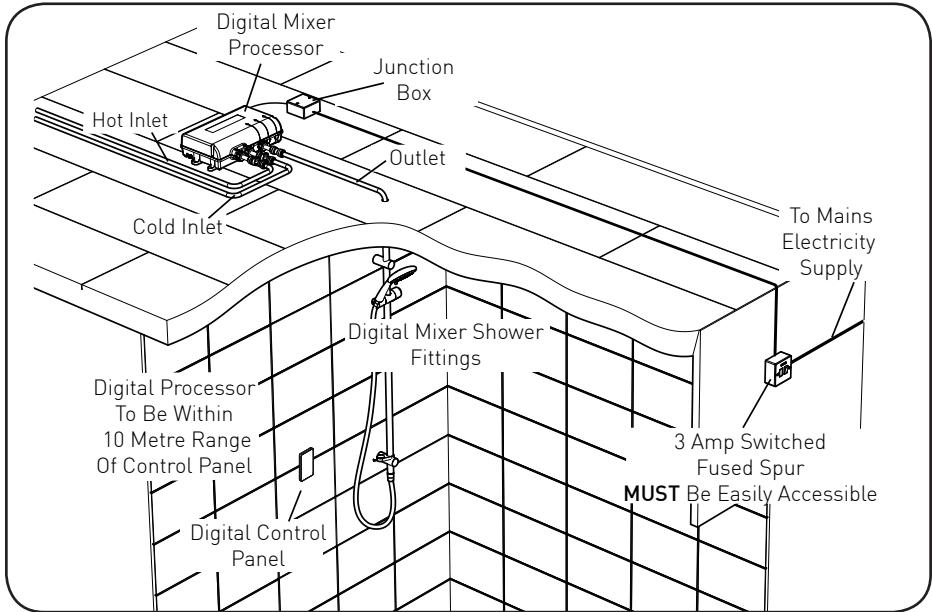

DO NOT install the Digital Mixer Processor where it can become frozen.

DO NOT install the Digital Mixer Processor where it can be subjected to ambient temperatures in excess of 40°C.

DO NOT position the Digital Mixer Processor where maintenance access is poor or unsafe.

DO NOT install the wireless Remote Start/Stop Button in a position where communication with the Digital Mixer Processor is poor e.g. installed under a metal bath, in front of a metal cistern, on foil backed plasterboard, outside of the 10 metre range.

DO NOT install the Digital Mixer Processor onto shared water supplies.

DO NOT fit plastic pipework unless rigidly supported.

DO NOT install the low pressure (gravity) Digital Mixer Processor less than 100mm from the lowest level of water in the cistern.

DO NOT install a high pressure/combination boiler Digital Mixer Processor to a low pressure pumped gravity system.

Digital Controller Installation

The Digital Controller is connected to the Digital Mixer Processor via a 10 metre data cable. The distance between the Digital Mixer Processor and Digital Controller **MUST** be within the range of the 10m data cable.

The Digital Controller has been designed to allow for the installation within a shower cubical or above a bath. The controller must be located whereby the user can start and stop the shower immediately.

DATA CABLE INSTALLATION

IMPORTANT: UNDER NO CIRCUMSTANCES SHOULD THE DATA CABLE BE EXTENDED OR SHORTENED, AS NOT ONLY WILL IT IMPAIR THE PERFORMANCE OF THE SHOWER, BUT IT WILL ALSO INVALIDATE THE GUARANTEE.

When connecting the Digital Controller to the Digital Mixer Processor using the data cable, the first operation is to connect the data cable to the Digital Mixer Processor.

Plug the ferrite end of the data cable into the Digital Mixer Processor. Ensure the arrow on the data cable connector points towards the front face of the processor unit. After connecting the data cable, tighten the screw collar to make a water tight seal **(FIG.13)**.

A 25mm diameter hole needs to be made within the showering area to allow for the data cable connection **(FIG.14)**.

Run the data cable from the Digital Mixer Processor to the showering area. Make sure there is enough slack cable at the controller end for the Digital Controller to be removed should the need arise for future maintenance. Approx. 150mm protruding length should be sufficient.

If the data cable is being routed through wall cavities, chased into solid walls or surface mounted then appropriate trunking/conduit **MUST** be used. Data cables **MUST** be fitted in such a way so that they can later be removed for maintenance or servicing.

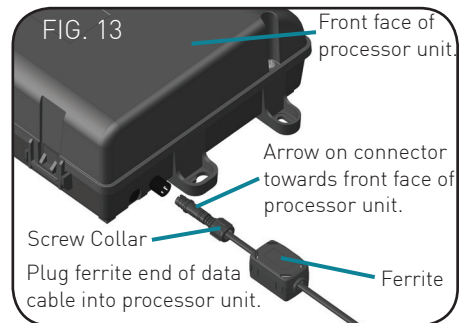

Digital Controller Installation

FIXING BRACKET INSTALLATION

Using the fixing bracket and a spirit level locate the bracket in the desired location, remembering to consider your cable routing position (**FIG. 14**).

Hold the fixing bracket in position and mark the top and bottom screw fixing holes (**FIG 14**). Remove the fixing bracket from the wall then drill and plug the wall for the fixing positions.

NOTE: An appropriate drill bit should be used. If the wall is brick, plasterboard or a soft building block, appropriate wall plugs and screws should be fitted.

Apply a small bead of silicone sealant around the $\varnothing 25\text{mm}$ hole, to seal the bracket to the wall (**FIG.15**)

Secure the fixing bracket to the wall using the appropriate fixings.

Whilst securing the fixing bracket to the wall, the data cable must be pulled through so that approx. 150mm protrudes from the wall, see (**FIG 14**).

Connect the data cable connector lead (**FIG.16**) from the Digital Controller to the data cable protruding from the fixing bracket.

Ensure arrows on connectors are aligned before connecting.

After connection, tighten screw collar to lock and seal connection.

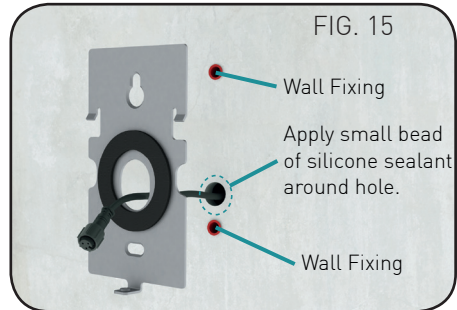
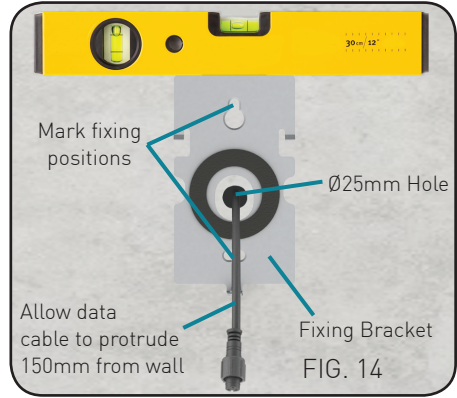

Digital Controller Installation

Align the fixing lugs on the back of the Digital Controller with the fixing lugs on the fixing bracket, then offer the Digital Controller up to the fixing bracket. Slide the Digital Controller upwards to engage the fixing lugs (**FIG.17**).

Whilst doing so push the excess data cable/data cable connection lead through the hole within the fixing bracket, and back into the wall cavity (**FIG.16**).



Insert and tighten the fixing screw in the bottom of the Digital Controller. **DO NOT** overtighten the screw (**FIG.18**).



Insert the the screw trim with the cut-out pointing towards the front of the Digital Controller (**FIG 19**).

DO NOT turn on the electricity supply to the Digital Mixer Shower until commissioning.

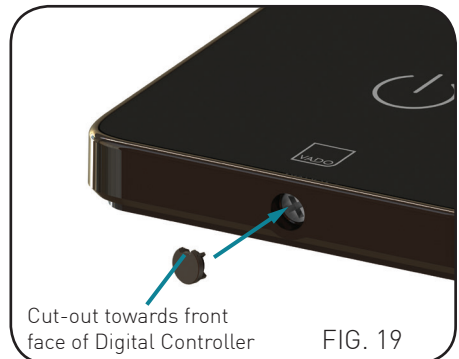

Commissioning

On first installation, commissioning is required to ensure water is purged through the unit and any air is dispelled from the system.

IMPORTANT: FAILURE TO COMMISSION THE DIGITAL MIXER SHOWER CORRECTLY COULD CAUSE LONG TERM DAMAGE TO THE SHOWER.

NOTE: While the Digital Mixer Shower is in Commissioning Mode all other functionality is locked out.

Commissioning **MUST** be carried out with suitable pipework/hose attached to the shower outlet and with the outlet directed to waste.

DO NOT run the low pressure Digital Mixer Shower (Pumped version) without a water supply for longer than 5 minutes.

PROCEDURE

1. Ensure that the isolating valves on the hot and cold inlets connectors are fully open (FIG.11 – Pg 16).
2. Turn on the water supplies and check the entire installation for water leaks.
3. Turn on the electrical supply to the Digital Mixer Processor.
4. The message in FIG.20 will be displayed on the Digital Controller.
5. Start the shower using the '**START/STOP**' control and allow to run for 5 minutes to prime both inlets and dispel any air from the system.
6. After 5 minutes, stop the shower using the '**START/STOP**' control.
7. Exit the Commissioning Mode by holding the '**FLOW -**' control (FIG.21) for 5 seconds. The shower is now ready for use.



FIG. 20



FIG. 21

Remote Start/Stop Installation

PAIRING THE REMOTE START/STOP

1. Remove the battery cover using the edge of a coin or similar. Twist anti-clockwise to unlock (**FIG.22**).
2. Install the supplied CR2032 Lithium 3V battery into the remote.
3. Replace the battery cover. Twist clockwise to lock.
4. Remove power to the Digital Mixer Processor for at least 1 minute.
5. Restore the power to the Digital Mixer Processor.
6. Within 2 minutes of restoring the power, press and hold the button on the remote **START/STOP** button for 15 seconds, then release.
7. Press the button on the remote **START/STOP** button to pair it with the Digital Mixer Processor.
8. The remote **START/STOP** button is now paired with the Digital Mixer Processor.
9. Test the remote **START/STOP** button functionality.
10. If the remote **START/STOP** button does not work, repeat steps 3-8.



INSTALLING THE WALL MOUNTING BRACKET

1. When selecting the location for the remote, check that the remote activates the unit before marking the wall.

NOTE: Do not install further than 10m from the processor unit

2. Mark the remote bracket in the position desired. Ensure that the bracket is flat when installed.
3. Drill and plug the hole, using a suitable screw, secure the bracket to the wall (**Fig.23**).
4. Press the supplied screw trim into the screw hole, ensuring its top surface is flush with the top surface of the bracket.
5. Offer the remote button up to the bracket and the remote should snap into place with a magnet.

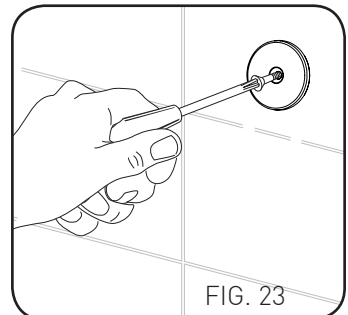

Quick Start

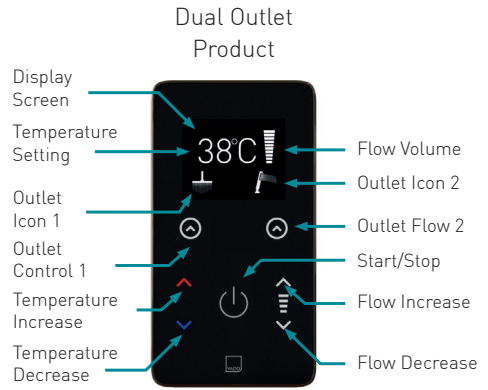
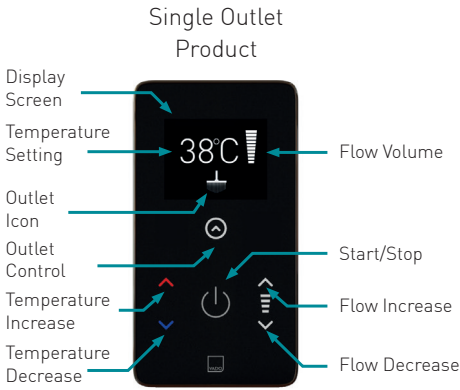

1. Touch the **'START/STOP'** control to activate the screen. Touch again to start the shower.
2. Turn outlets On/Off using the corresponding **'OUTLET'** controls. If all outlets are turned to Off, the shower will return to Sleep Mode.

3. Increase water temperature.
4. Decrease water temperature.
5. Increase flow.
6. Decrease flow.

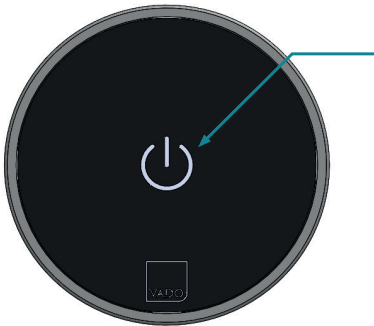

REMOTE START/STOP

Turn outlets On/Off using the **'START/STOP'** button.

Single click to turn outlet 1 On/Off.

Double click to turn outlet 2 On/Off.

Press & hold for 3 seconds to stop all running outlets.

If all outlets are turned to Off, the shower will return to Sleep Mode.

NOTE: Outlet 2 is available on dual outlet-products only. Outlet controls and icons will vary according to the product configuration.

General Maintenance

If the Digital Mixer Processor is dismantled for any reason during servicing or maintenance, then it **MUST** be inspected to ensure there are no leaks, it is also advised to follow the commissioning procedure to ensure no air has become trapped during the work.

CLEANING

Many household cleaners contain abrasive and chemical substances, and should not be used for cleaning the Digital Controller or any chrome plated fittings. It is recommended that your Digital Mixer Shower system is cleaned regularly with warm, soapy water using a micro fibre cleaning cloth (eg: E-cloth) or sponge **ONLY**.

DO NOT use a general purpose cleaning cloth (eg: J-cloth) dish cloth or scourer.

DO NOT use abrasive or aggressive chemical cleaning products as this may affect the product surface finish and invalidate your guarantee.

It is recommended that the filter is periodically cleaned in order to maintain the performance of the shower. It is essential that this operation is carried out by a competent person.

CLEANING THE FILTERS

1. Using an appropriate flat bladed screwdriver, isolate both the hot and cold inlet valves (**FIG. 11 Pg 16**).
2. Isolate the electricity supply to the Digital Mixer Processor.
3. Unscrew the inlet nut and remove the inlet pipe, O ring seal, flow regulator housing/Inlet filter.
4. Remove the inlet filter from the flow regulator housing (**FIG.24**) and wash thoroughly under running water to remove all debris.
5. Refit the flow regulator housing/
Inlet filter, O ring seal and inlet pipe,
secure with the inlet nut.

NOTE: The inlet nut only requires to be hand tightened.

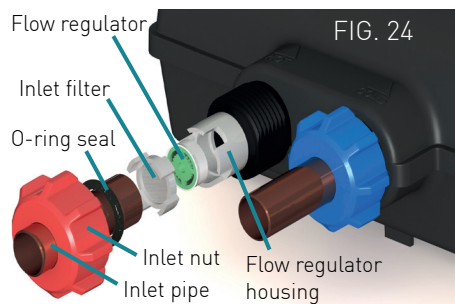

Spare Parts

	DESCRIPTION	CODE
1	Temperature Control Valve (Low Pressure)	83316750
	Temperature Control Valve (High Pressure)	83316760
2	Digital Mixer Processor PCB (Single Outlet)	7073756
	Digital Mixer Processor PCB (Multi Outlet)	7073763
3	Temperature Control Motor	22013594
4	Flow Control Valve	83316770
5	Flow Control Motor	22013595
6	Thermistor Assembly	83316780
7	Solenoid Assembly & O Ring Seals	83316800
8	Pump Assembly (Low Pressure Product Only)	83316790
9	Check Valve & Inlet Filter Pack	83316810
10	Digital Controller (inc. fixing bracket & screw)	A31820500
11	Digital Controller Fixing Screw	20801180
12	Digital Controller Fixing Bracket	P86005000
13	10m Data Cable	2160636
14	VADO Remote Start/Stop (inc. bracket)	A31860500



Fault Diagnosis

If any maintenance is required then it **MUST** be carried out by a competent trade person or a VADO Engineer. **ENSURE** that the underlying cause of malfunction is resolved before replacing any parts.

IMPORTANT: ISOLATE THE ELECTRICITY SUPPLY AND REMOVE THE CIRCUIT FUSE BEFORE ATTEMPTING ANY FAULT DIAGNOSIS INSIDE THE DIGITAL MIXER PROCESSOR.

Symptom	Problem	Action / Solution
Digital Mixer Shower will not turn on/no water flow	Interrupted power supply	Blown fuse or circuit breaker. Check supply Renew or reset fuse or circuit breaker. If it fails again, consult a qualified electrician. Power cut? Check other appliances and if necessary, contact local Electricity Supply Company
	Inlet Isolating valves not fully open	Check if isolating valves are fully open
	Inlet filters or check valves blocked	Check for a blockage, refer to 'Maintenance Pg 25'
	Air lock in water supplies (LP unit only)	Purge air from hot and cold supplies to the connectors on the mixer unit, see 'Commissioning Pg 22'
	Failure of either water supply	Check water elsewhere in the house and, if necessary, contact the local water company
	Unit malfunction	Contact VADO Customer Service
Low Flow Rate	Blocked shower head or hose	Clean sprayplate or replace blocked hose
	Inlet water pressure low	Check if sufficient water pressure, see 'Specification Pg 6'
	Air lock in Digital Mixer Processor unit	Prime to remove air from the mixing unit, see 'Commissioning Pg 22'
	Hot inlet flow regulator not suitable/wrongly fitted	Check and refer to 'Typical Suitable Installation Pg 10'
	Flow setting too low	Increase flow by pressing the flow increase button, see 'Quick Start Pg 24'
	Inlet Isolating valves not fully open	Check if isolating valves are fully open
	Blockage in inlet filters or check valves	Check for a blockage, refer to 'Maintenance Pg 25'
Low Flow Rate (cont)	Blockage in pipework	Turn off the shower and consult a suitably competent plumber

Fault Diagnosis

Symptom	Problem	Action / Solution
Shower Pulsing (HP mixer unit on combination boiler)	Water supply temperature too low	Increase domestic hot water temperature
	Unbalanced water pressures	Fit a pressure reducing valve in the cold supply to the mixer and set to the same pressure as the hot supply
Water too cool or cold	Temperature setting too low	Increase temperature via touch temperature control. See ' Quick Start Pg 24 '
	'Max Shower Temp' setting set to low	Increase Max Shower Temp setting, refer to ' Configuration Mode Pg 9 ' in the User Guide
	Supply temperature below 50°C	Set system temperature to a minimum of 55°C, see ' Specification Pg 6 '
	Water pressure above maximum specified or imbalanced	Check water pressures are normally equal, refer to ' Specification Pg 6 '
	Combination boiler cutting in/out	Check the use of flow regulators, see ' Typical Suitable Installations Pg 10 '
	Insufficient supply of stored hot water	Check storage capacity of hot water, see ' Typical Suitable Installations Pg 10 '
	Air lock in Digital Mixer Processor unit (LP unit only)	Prime to remove air from the mixing unit, see ' Commissioning Pg 22 '
	Inlet supply connection reversed	Check and if necessary correct, see ' Digital Mixer Processor Installation Pg 14 '
Shower stops during showering	Outlet pipe run is too long	Ensure outlet pipe is thermally lagged, see ' Digital Mixer Processor Installation Pg 14 '
	Maximum showering time reached	Restart the shower by pressing the ' START/STOP ' button, refer to ' Configuration Mode Pg 9 ' in the User Guide
Shower stops during showering	Loss of either water supply	Check water elsewhere in the house and, if necessary, contact the local water company
		Check that water is available to the shower when other outlets are in use
		Wait for stored water to reach temperature
Shower stops during showering (cont)	Air lock in Digital Mixer Processor unit	Check for correct installation, repeat priming to remove air from the mixing unit, see ' Commissioning Pg 22 '
	Combination boiler cutting in/out	Check the use of flow regulators, see ' Typical Suitable Installations Pg 10 '

Fault Diagnosis

Symptom	Problem	Action / Solution
Noise	Air lock in Digital Mixer Processor unit	Check for correct installation, repeat priming to remove air from the mixing unit, see ' Commissioning Pg 22 '
	Water hammer	Ensure all pipework is securely fixed, see ' General Installation Information Pg 9 '
	Unit malfunction	Contact VADO Customer Service
Digital Control Panel is not very responsive	Unit malfunction	Contact VADO Customer Services

Disposal & Recycling

Spent batteries should **NOT** be disposed of with your normal household waste.

NEVER dispose of batteries in fire as this may cause them to explode.

ALWAYS dispose of batteries in an environmentally friendly manner and in accordance with local regulations.





SENSORI

SMARTTOUCH

MY SHOWER IS NOT WORKING, WHAT DO I DO?

Customer service is only a phone call away. If you experience any problems with your new shower during its guarantee period then simply call:

01934 745163

